

# JD-5,JD-6

JD Series Motor Integrated Protector

## OPERATION INSTRUCTION

Standard: IEC 60947-4-1

**CNC**

Deliver  
Power For Better Life

-  Before installing and using this product, please read this instruction carefully and pay more attention to safety.

# JD Series Motor Integrated Protector Instructions

## 1. General

JD series motor integrated protector, suitable for power supply circuit with AC 50/60Hz, voltage 380V and below. JD series and AC contactor and other switching circuit to form motor control circuit. When the main circuit of the motor is out of phase, overload and other abnormal working state, the switch contact can be disconnected in time, the three-phase power supply of the motor is cut off, and the motor can be protected reliably.

Standard: IEC 60947-4-1.

## 2. Type designation

JD-□ /□ □

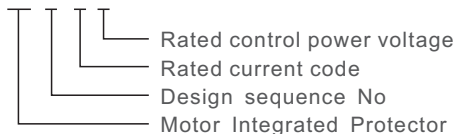

### 3. Operating conditions

- Altitude  $\leq 2000\text{m}$
- Ambient temperature Range:  
-5°C ~ +40°C, with daily average  $\leq +35^\circ\text{C}$
- Pollution Level: Level 3
- Inclination between installation plane and vertical plane shall  $\leq \pm 5^\circ$
- In the media without explosive risk, and no gases that may be corrosive to metal and damage insulation in the media together with at places where much conducting dust being in existence
- At places where rain & snow proof facilities are equipped with and not being full of steam
- At places without prominence rock, impact and vibration
- Installation Category: III

## 4. Technical data

Rated insulation voltage AC690V, rated frequency 50Hz, rated operating current 0.5A~300A.

Parameter	Model	JD-5	JD-5B (with buzzer)	JD-6	BHQ-S-C	BHQ-S-J
Rated Voltage	AC380V 50Hz(Other voltage levels can be customized)					
Setting current range (suitable motor power)	2-100A (1-50KW)	2-100A (1-50KW)	60-250A (160-400KW)	20-100A,60-250A 160-400A	0.5-5A 5-20A	
Overload action time (with inverse time limit characteristics)	3-300s(Adjustable)					
Phase failure action time	≤2s					
Reset Mode	De-energizing reset					
Contact capacity	AC380V 3A					
Display mode Alarm mode	LED Light indication Sound-light alarm					
Mechanical life	10 <sup>6</sup>					
Electric life	10 <sup>5</sup>					
Installation mode	Screw					

## 5. Wiring diagram

5.1 Please read the instruction carefully and connect the cables correctly according to the wiring diagram;

5.2 JD-5, JD-5B: Terminal 1、 2 is power input, 3、 4 is the normally closed contact;

JD-6: Terminal 4、 5 is power input, 2、 3 is the normally closed contact, 1、 3 is the normally open contact. Please refer to the wiring diagram. The three lines of the output end of the AC contactor are connected with the motor through the three white lead holes H1、 H2、 H3 of the protector, see the wiring diagram.

5.3 Rotate the two knobs on the front panel of protector clockwise to maximum, check the wiring is correct and power on, press the start button, motor running, ( green light on when normal, yellow light on when phase failure, red light on when overload), after running normally, then rotate current adjusting knob counterclockwise, until the overload light flashing, then fine-tuning clockwise to critical position when overload light not flashing; And observe for about 3 minutes, during which the current or the motor and the load are normal, the overload light does not flash, and then turn the delay knob counterclockwise back to the position greater than the motor starting time (longer is better); After normal rotation of the motor, the overload light is not on, and then the motor is manually loaded, At this time, the overload light flashes, and the whole debugging process is completed.

## Wiring diagram for control power supply @ AC380V voltage

JD-5, JD-5B, BHQ-S-J, BHQ-S-C(2~100A)

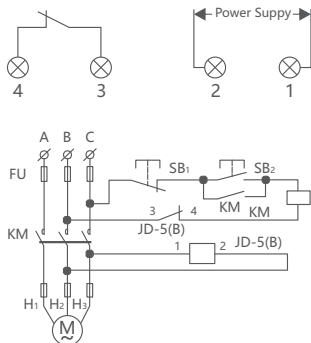

JD-6, BHQ-S-C(60~250A, 160~400A)

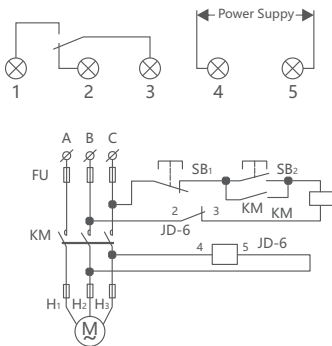

## Wiring diagram for control power supply @ AC220V voltage

JD-5, JD-5B, BHQ-S-J, BHQ-S-C(2~100A)

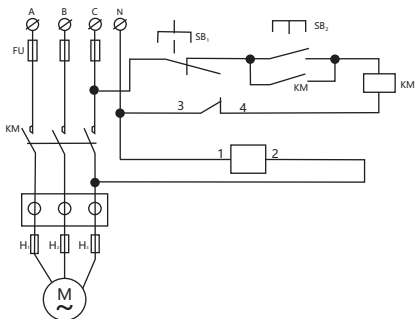

JD-6, BHQ-S-C(60~250A, 160~400A)

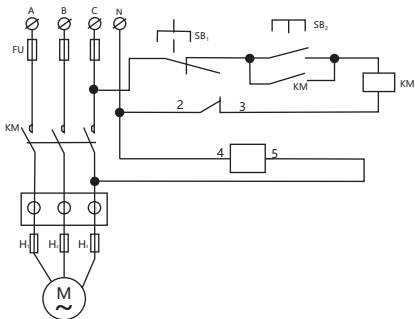

## 6. Overall and mounting dimensions(mm)

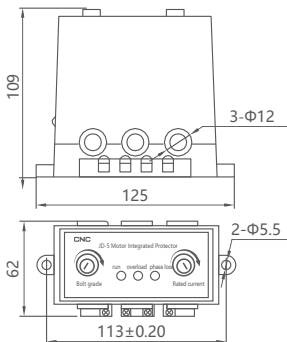

JD-5(B), BHQ-S-J, BHQ-S-C (2~100A)

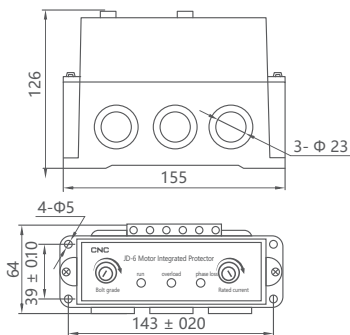

JD-6, BHQ-S-C(60~250A, 160~400A)



## 7. Precautions for Operation

7.1 When debugging the current knob, the change of rated working voltage should be less than  $\pm 5\%$

7.2 For JD-5 and JD-5B, motors whose line current is less than 6A (JD-6, line current is less than 63A), the three-phase power line should be looped through the white wire hole of the protector for several turns in the same direction, and the small no-load line current of the motor should be considered. Technical data requirements shall be met.

7.3 Due to the internal structure, the over current adjustment scale is not linear. Please refer to the actual debugging.

7.4 Check the protector performance regularly, such as phase failure test, overload test, etc.

7.5 It is strictly prohibited to increase the current potentiometer of the protector when the current and the motor or the load is abnormal, because it is easy to burn the motor.

7.6 For the equipment that may cause significant economic loss or personal safety, make sure that the technical characteristics and performance value have enough allowance, and adopt safety measures such as double circuit protection.

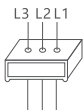

1 turn when more than 2A

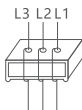

2 turns when 1-2A

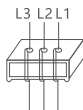

4 turns when 0.5-1A

## **8. Common faults and troubleshooting methods**

8.1 In case the motor stops during operation, carefully check whether there is a phase failure or overload, and check whether the temperature of the motor rises very high first. If there is a temperature rise, the motor may stop due to overload. If there is no temperature rise, it may be phase failure causing tripping, check whether the three-phase power supply is normal; Whether the dynamic and static contacts of the AC contactor are in good contact, and whether the three power lines of the motor are loose; If the motor still cannot start after everything is normal, it is necessary to carefully check whether the self-locking contact of the AC contactor and the connection screw of the normally closed contact of the protector are loose and other reasons. The motor can be started until the fault is removed. When the fault is not removed, can not start the motor forcibly to avoid accidents.

8.2 The protector shall be used in conjunction with the motor and load switch (such as contactor), and the power supply shall be switched on synchronously. If the power supply is not switched on synchronously, the protector shall appear phase failure fault, and the motor cannot be started normally.

8.3 When a fault occurs, disconnect the power supply first, find the cause of the fault, check the circuit and follow the instructions for installation and operation;

8.4 If the product has quality problems, please contact the local distributor or our company.

## **9. Transportation and storage**

Product storage and transportation process can not be affected by rain and snow, and extrusion, should be placed in the air circulation, relative humidity ( $25^{\circ}\text{C}\pm 5^{\circ}\text{C}$ ) does not exceed 90%. The lower temperature is  $-25^{\circ}\text{C}$ , and the upper temperature is  $+55^{\circ}\text{C}$ .

## **10. Unpack and check**

Open the carton and check the instruction manual inside the carton.

## **11. Ordering instructions**

JD-5B has one more fault alarm buzzer than JD-5, other performance is exactly the same, the current of JD-5/JD-5B is 2-100A; JD-6 current is 60-250A,160-400A; Please note that the motor power is consistent with the protector. When ordering, please indicate the model and specification of the product. For special requirements, please consult with the manufacturer.

## **12. Company commitment**

Under the premise that the user complies with the conditions of use and storage and the seal of the product is in good condition, the company shall repair or replace the product free of charge if the product is damaged or cannot be used normally due to manufacturing quality problems within 24 months from the production date. If the warranty period is exceeded, it shall be repaired with compensation. However, if the damage is caused by the following circumstances, it shall be repaired with compensation even within the warranty period:

- (1) Improper use, maintenance or storage;
- (2) self-refitting or improper repair;
- (3) damage occurs after purchase due to falling or during installation;
- (4) Force majeure such as earthquake, fire, lightning strike, abnormal voltage and secondary disasters;
- (5) The electrical life of the product exceeds 100,000 times; Mechanical life more than 1 million times;



# CERTIFICATE

Product Model: JD-5,JD-6

Inspector : CNC 001

Production date: Printed on the product  
or package.

This product is qualified according  
to the delivery inspection

## CNC ELECTRIC

Tel: 0086-577-61989999 Fax: 0086-577-61891122

wwwcncele.com E-mail: cncele@cncele.com

A vertical red bar containing the white text 'CNC'.

JD-5 JD-6 series